

# LOTUS

B1F

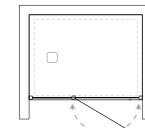

-Porta per nicchia battente - Pivot niche  
- Frontal pivotante - Porta batente



COD.	↔ cm	A cm	B cm	Kg	n°	finiture profili profiles finishings acabados de perfil acabamentos de perfil		finiture vetro - glass finishings - acabados de vidrio - acabamentos de vidro			
						F (€)	N (€)	H - J - V - C - W (€)			
Lotus B1F / 90 LOB1F090/___	86 - 91	48	30	37	1	5	•	•••	•••		
						6	•••	•••	•••		
Lotus B1F / 100 LOB1F100/___	96 - 101	53	35	39	1	5	•	•••	•••		
						6	•••	•••	•••		
Lotus B1F / 110 LOB1F110/___	106 - 111	58	40	22	2	5	••	•••	•••		
						6	•••	•••	•••		
Lotus B1F / 120 LOB1F120/___	116 - 121	63	45	24	2	5	•	•••	•••		
						6	•••	•••	•••		
Lotus B1F / 130 LOB1F130/___	126 - 131	73	50	26	2	5	•••	•••	•••		
						6	•••	•••	•••		
Lotus B1F / 140 LOB1F140/___	136 - 141	73	55	28	2	5	••	•••	•••		
						6	•••	•••	•••		
Lotus B1F / 150 LOB1F150/___	146 - 151	73	65	31	2	5	•••	•••	•••		
						6	•••	•••	•••		
Lotus B1F / 160 LOB1F160/___	156 - 161	73	75	34	2	5	•••	•••	•••		
						6	•••	•••	•••		
Lotus B1F / 170 LOB1F170/___	166 - 171	73	85	38	2	5	••	•••	•••		
						6	•••	•••	•••		
Lotus B1F / 180 LOB1F180/___	176 - 181	73	95	41	2	5	•••	•••	•••		
						6	•••	•••	•••		

Disegni tecnici - Technical drawings  
Dibujos técnicos - Desenhos técnicos

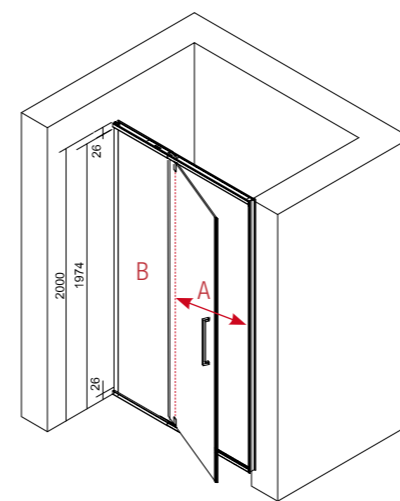

Profili a muro - Wall profile  
Perfiles de pared - Perfis de parede

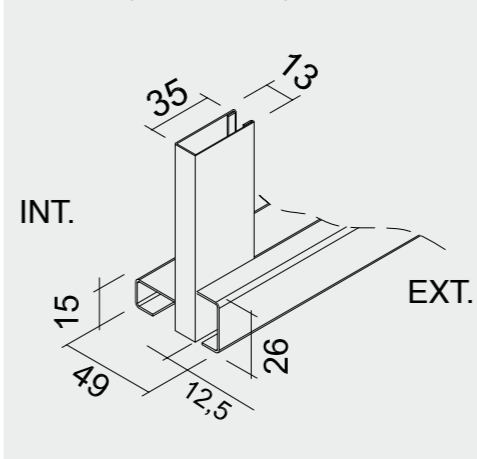

Alcuni componenti saranno sempre con finitura lucida  
Some components will always be with glossy finish  
Algunos componentes siempre estarán con acabado brillante  
alguns componentes terão sempre acabamentos brilho

Materiali e finiture - Materials and finishings - Materiales y acabados - Materiais e acabamentos

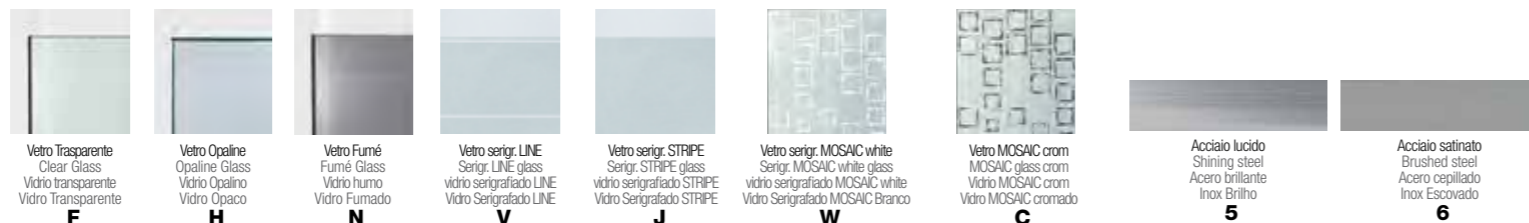

Caratteristiche tecniche - Technical features - Características técnicas - Características técnicas

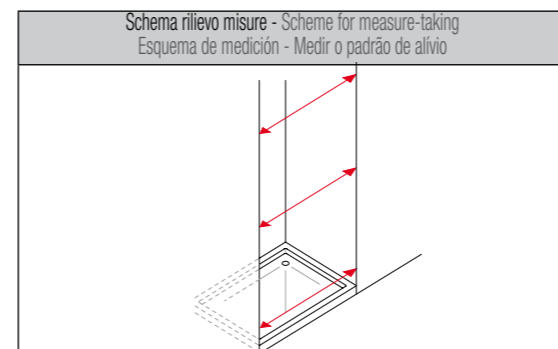
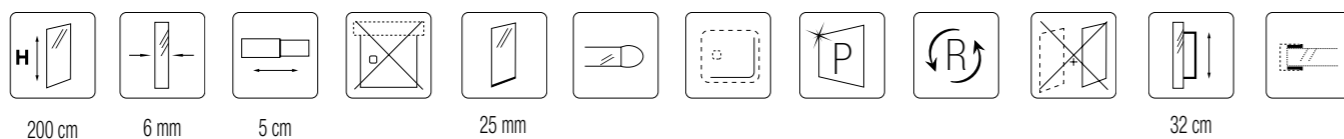

Per una corretta installazione è necessaria una zona piana min. 40 mm. in corrispondenza del profilo base  
For a correct installation requires a flat area min. 40 mm. in correspondence of the base profile  
Para una correcta instalación requiere un área plana min. 40 mm. en correspondencia con el perfil de base  
Antes de uma instalação correcta, um plano de plano min. 40 mm. em correspondência com o perfil de base

Prodotti speciali - Special products - Medidas especiales factibles - Medidas especiais				
↑ altezza cm. height cm. Altura cm. Altura cm.	max	210		
	standard	200	+20%	
	min	190	+10%	+20%
↔ larghezza considerata ad estensibilità minima width considered to extensibility minimum largear considerado extensibilidad minimum Ervellerbarkeit Mindest angesehen			86	176
			min	max

TECNOVETRO

Maggiori info pag. 9 - More info page 9  
Más información pag. 9 - Mais informações pag 9